







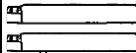

Ripley Chair Assembly

You're Furnished

NO.	PARTS	QTY
A	Back 	X1
B	Seat 	X1
C	Front legs 	X2
D	M8x70mm 	X4
E	M8x50mm 	X4
F	Flat washer 	X8
G	Spring washer 	X8
H	Allen key 	X1

Lay part A (back) on its' back and push part B (seat) up the two back legs until the holes line up with the thread

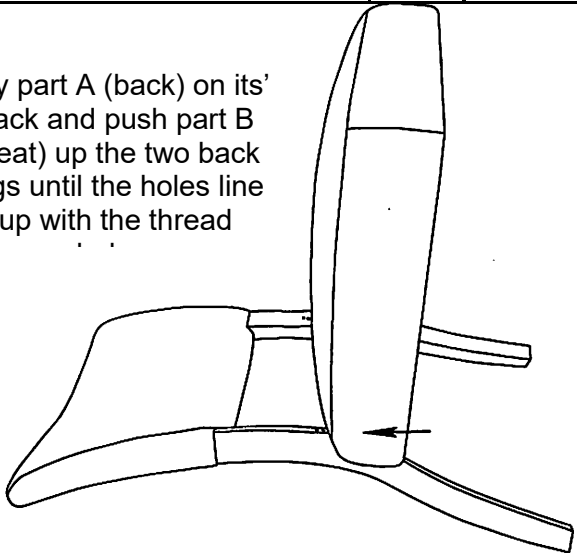

STEP 1

Turn the chair upside down and insert the two part C (legs) into the front of the seat pad with the grooves facing away from the chair. Insert parts D, G and F through the holes that go into part C (legs) Repeat the same process with parts E, G and F into the holes going into part A ensuring all bolts are only **loosely** tightened.

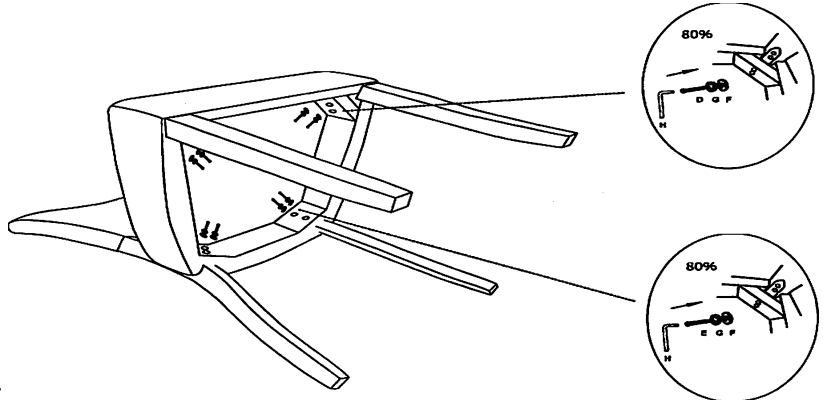

STEP 2

Place assembled chair on flat surface, applying at least 60kg of pressure on the chair base.

Adjust until all 4 legs are level and then tighten the screws up.

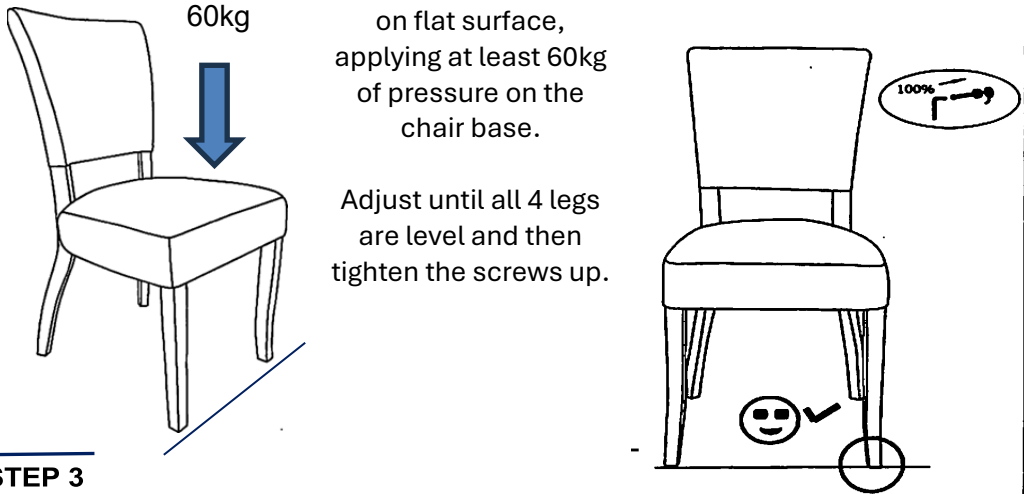

STEP 3